

516F-9a solid state power supply substitute to the 516F-2 Collins power supply F6EXG

As a Collins collector, I always criticized the original 516F-2 power supply, for the KWM-2(a), 32S-n i.e.

- It becomes hard to find on the second hand market,
- It operates from 115V mains,
- And “stabilization” comes from bleeders. Warming up the shack is good in winter, but less in summer!

Therefore, the idea came to design a solid state voltage rectification and stabilization which would take care of the P.A, (high voltage and bias) and the low voltage circuits (receiver and transmitter).

Providing getting a 230V customer defined transformer from a transformer company, we do not need “bleeders” nor filter inductors.

The following figure shows the functional diagram of this design:

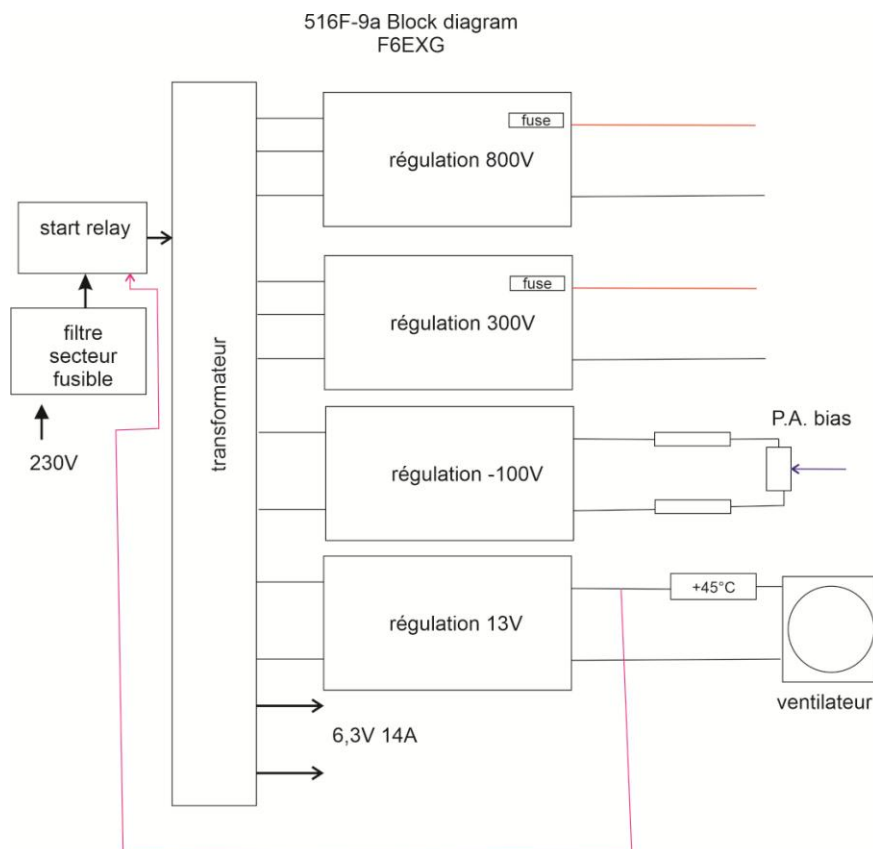

The main functions are placed on a double layer P.C.B., except the mains filter, fuse, ON/OFF start relay (protecting the transceiver's ON switch!), thermal switches, and transformer (of course!), fan, heatsink etc. see the following figure:

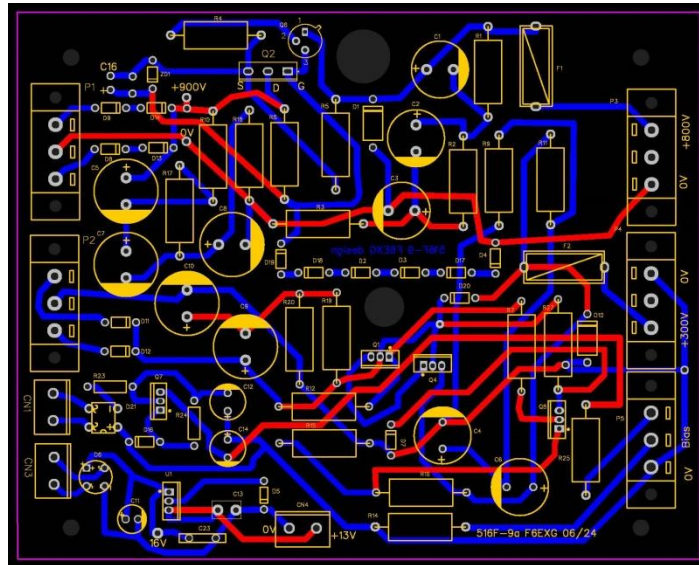

3-D representation:

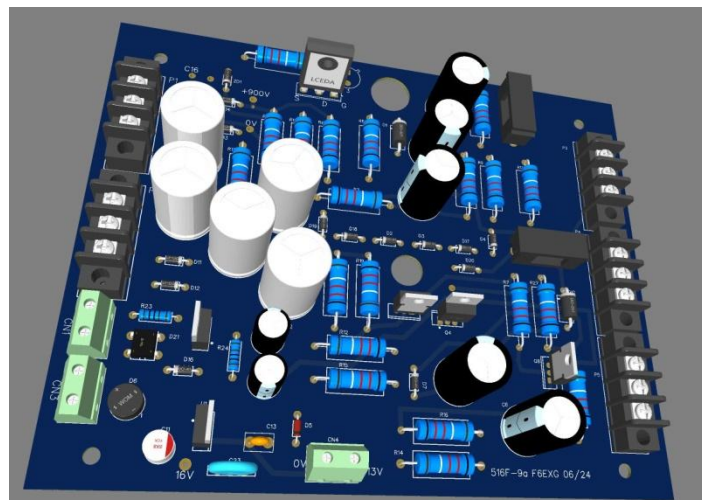

Chassis prototype:

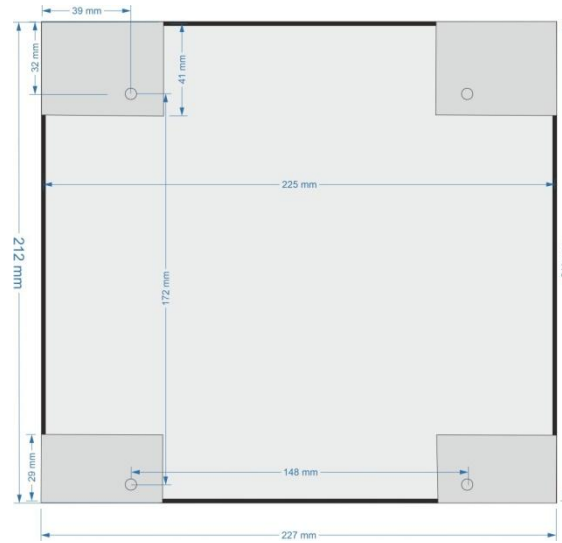

It fits in the original grey Collins box.

Prototype photos:





ON/OFF relay:

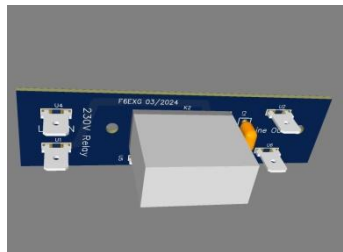

This build is meant for electronics engineers since it involves high voltages.

F6EXG

18/04/2024



www.ccae.info